



SINCE 1908
wessels
 company

SUBMITTAL

WVA GROOVED-SERIES

AIR & DIRT SEPARATOR

Models: WVA-2G thru WVA-12G

Submittal Sheet No. D-1014A

Date: 8/16

Job Name _____	Submitted By _____	Date _____
Location _____	Approved By _____	Date _____
_____	Order No. _____	Date _____
Engineer _____	Notes _____	_____
Contractor _____	_____	_____
Sales Rep. _____	_____	_____

Description

Wessels WVA-G Grooved series ASME Air & Dirt Separators are designed to eliminate entrained air and separate debris associated with start-up and maintenance of any hydronic system. The design incorporates a skim valve that is used to eliminate floating debris, a removable end cover for coalescing medium access, and an air vent to automatically release air from the separator.

Construction

Shell: Carbon Steel
 Coalescing Medium: Stainless Steel
 Blow Down Valve (optional): Brass
 Skim Valve (optional): Brass
 Vent (optional): Cast Iron

Performance Limitations

Maximum Design Temperature: 250°F
 Maximum Design Pressure: 150 PSIG*

*125, 200, & 250 PSIG available

Model Number	Part Number	Max Flow (GPM)	Tagging Information	Quantity
WVA-2G	72302023	69		
WVA-2.5G	72302057	108		
WVA-3G	72302091	144		
WVA-4G	72302125	255		
WVA-5G	72302148	398		
WVA-6G	72302171	570		
WVA-8G	72302194	945		
WVA-10G	72302217	1440		
WVA-12G	72302240	2100		

Typical Specification

Furnish and install, as shown on plans, a WVA-_____ G Air & Dirt Separator as manufactured by Wessels Company. Each separator must be designed with a blow down valve, skim valve, and automatic air vent. The separator must also utilize in its design a stainless steel coalescing medium to aid in the separation of air and dirt in the systems entrained water. The separator must be constructed in accordance with most recent addendum of Section VIII Division 1 of the ASME Boiler and Pressure Vessel Code and shall be constructed and stamped for 150 PSI working pressure @ 250°F.

Each air separator shall be Wessels model number WVA-_____G or approved equal.

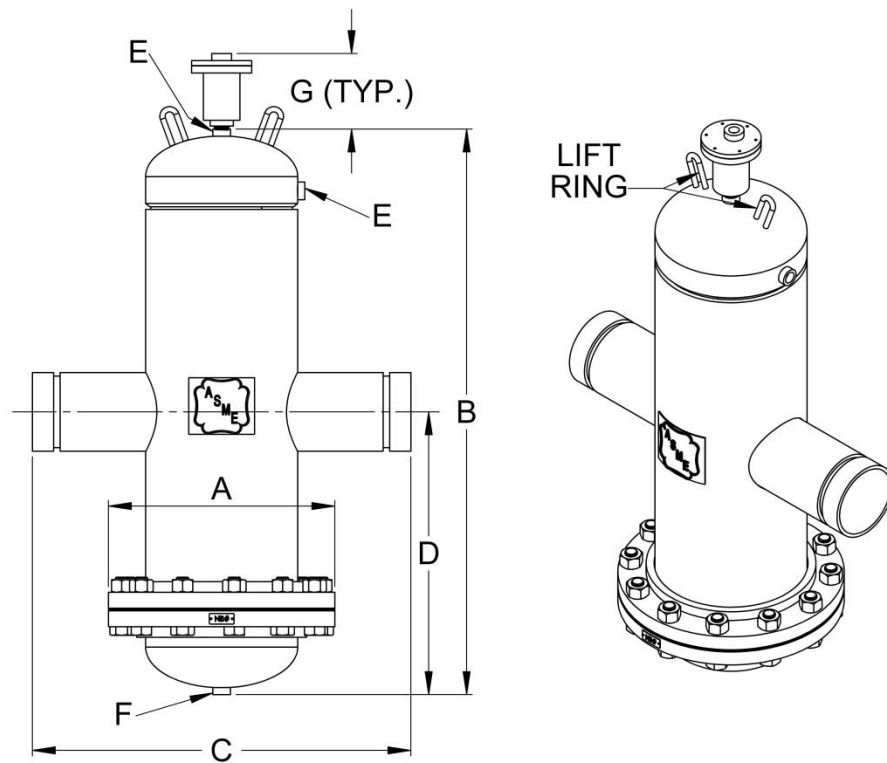

WVA-2G thru WVA-12G

Dimensions & Weights

Model Number	Dimensions in Inches								Approx Shipping Wt (lbs)
	Connection Size	A	B	C	D	E	F	G	
WVA-2G	2	9	23	15 1/4	11 1/2	1/2	1/2	8 5/8	100
WVA-2.5G	2.5	10		15 3/4					125
WVA-3G	3	11	20 1/4	14 1/2	150				
WVA-4G	4	13 1/2			20 5/8				250
WVA-5G	5	16	39	27 3/4	19 1/2		310		
WVA-6G	6	19					375		
WVA-8G	8	23 1/2	49	33 5/8	24 1/2		1		700
WVA-10G	10	27 1/2	65	37 1/2	32 1/2				1000
WVA-12G	12	32	76	42 1/2	38	1500			

Notes

- Trim package is optional.