

SINCE 1908
wessels
company

SUBMITTAL

WESSGUARD®
 Bladder Integrity Monitor

Model: WG-1ZONE

Submittal Sheet No. N-1002A Rev. 1 2/11/2021

Job Name _____	Submitted By _____	Date _____
Location _____	Approved By _____	Date _____
_____	Order No. _____	Date _____
Engineer _____	Notes _____	_____
Contractor _____	_____	_____
Sales Rep. _____	_____	_____

Description:

Wessels Company's patented WessGuard® bladder monitor is a smart tank add-on that provides essential protection by alerting you early before you have a maintenance issue with your expansion tank. Expansion tanks are designed to absorb the expansion forces and control the pressure in HVAC, domestic hot water, and well and pressure booster systems. The system's expanded water (fully compatible with water/glycol mixtures) is contained in a heavy-duty bladder preventing tank corrosion and waterlogging problems. If the bladder extends beyond the normal movement, the WessGuard® monitor will activate an audible and LED alarm to notify maintenance staff of a potential system issue. The WessGuard® also features a dry set of contacts, making it fully Energy Management System (EMS) compatible.

Construction:

Enclosure: Plastic
 System Connection: NPT (For the Sensor)

Design Parameters:

24Volt Control Voltage.
 Coverage-by-Percentage Alarm Sensor.
 Direct Input to BMS compatible.

Model Number	Part Number	Tagging Information	Quantity
WG-1ZONE	99A1700		

Typical Specification

Furnish and install, as bshown on plans, a WessGuard® Bladder Integrity Monitor with 24Volt control, 1" NPT Sensor connection, audible alarm sensor, set of dry contacts, plastic enclosure and tank attachment bracket.

Each WessGuard® shall be Wessels model number WG-_____ or approved equal.



SINCE 1908
wessels
company

101 Tank Street Greenwood, IN 46143
 P: 317-888-9800 F: 317-865-7411
 www.westank.com

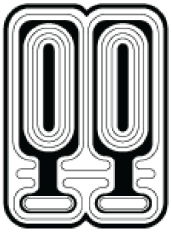

SINCE 1908
wessels
 company

SUBMITTAL

WESSGUARD®
 Bladder Integrity Monitor

Models: WG-1ZONE

Submittal Sheet No. N-1002A Rev. 1 02/11/2021

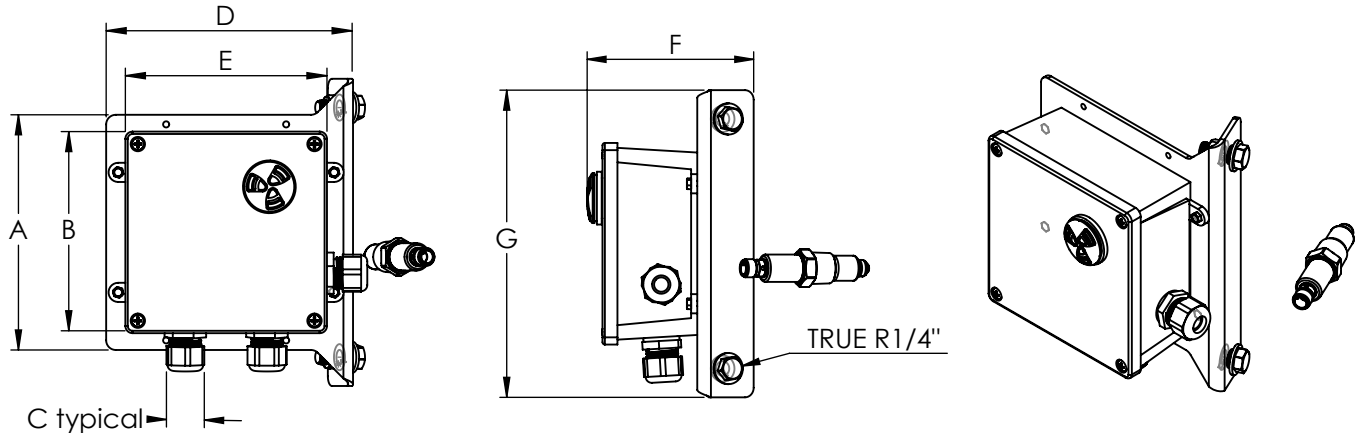

Dimensions & Weights:

Model Number	Dimensions in Inches							Approx. Shipping Weight (lbs)
	A	B	System Connection	D	E	F	G	
			C					
WG-1ZONE	6 1/8"	5 3/16"	1"	6 7/16"	5 1/4"	4 5/8"	8"	3

Notes:

- U.S. Patent No. 8,633,825 B2
- Set of Dry Contacts BMS Compatible



SINCE 1908
wessels
 company

101 Tank Street Greenwood, IN 46143
 P: 317-888-9800 F: 317-865-7411
 www.westank.com